

E200 ORT series
Torque Transducer
10mNm to 500Nm

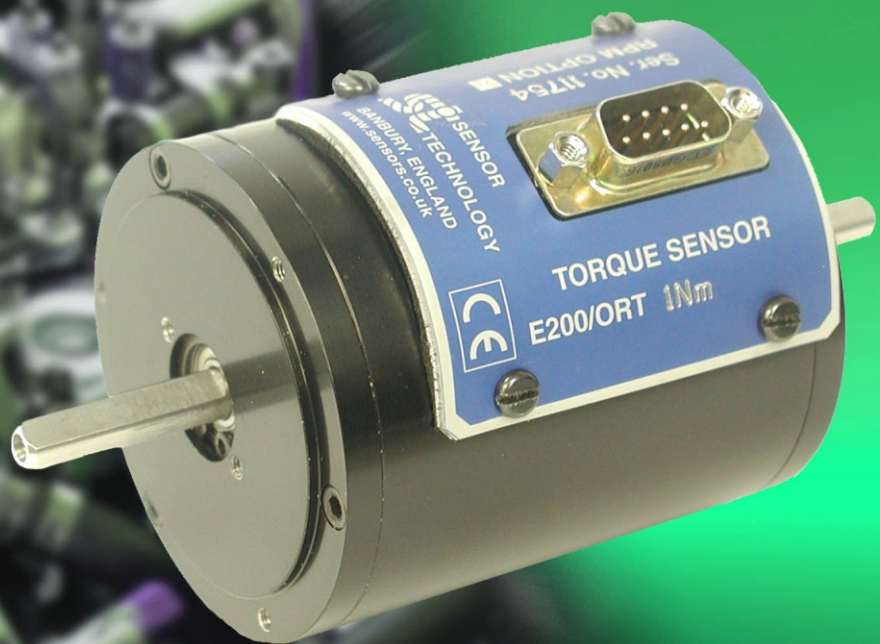

E200 ORT Series Optical Rotary Torque Transducer

The E200 ORT Series (Optical Rotary Torque) Transducer offers, in conjunction with an E201/2 Display Interface, an ideal means for precise dynamic measurement of rotary and static torque less than 500Nm and for bandwidths up to 50KHz.

Benefits

- Operates both statically and dynamically clockwise/anticlockwise
- Non contact measurement
- High bandwidth (up to 50KHz)
- 200% safe mechanical overload
- Low inertia High Speed capability
- E200 ORT Transducers are compatible with our older D Series Instrumentation
- Lifetime warranty

Software

TorqView is an easy to use advanced torque monitoring software available to assist data recording and instrumentation displays that interfaces with Windows based PCs. See TorqView datasheet.

Features: 3 types of display. Text files compatible with Matlab and Excel. Real time chart plotting.

LabView VIs are available for users to design their own process control applications.

DLLs are also available for users to write own custom software.

Standard Specifications

Model	Full Scale Deflection (Calibration in any of the units below is possible)						Max Speed (RPM)	Shaft type
	S.I		F.P.S		M.K.S			
E200ORT-1S	0-10	mNm	0-1	ozf.in	0-100	gf.cm	30,000	P
E200ORT-2S	0-20	mNm	0-2	ozf.in	0-200	gf.cm	30,000	P
E200ORT-1	0-50	mNm	0-5	ozf.in	0-500	gf.cm	30,000	P
E200ORT-2	0-100	mNm	0-10	ozf.in	0-1	kgf.cm	30,000	P
E200ORT-3	0-200	mNm	0-20	ozf.in	0-2	kgf.cm	30,000	P
E200ORT-4	0-500	mNm	0-50	ozf.in	0-5	kgf.cm	30,000	F
E200ORT-5			0-100	ozf.in			30,000	F
E200ORT-6	0-1	Nm	0-10	lbf.in	0-10	kgf.cm	30,000	F
E200ORT-7	0-2	Nm	0-20	lbf.in	0-20	kgf.cm	20,000	K
E200ORT-8	0-5	Nm	0-50	lbf.in	0-50	kgf.cm	20,000	K
E200ORT-9	0-10	Nm	0-100	lbf.in	0-100	kgf.cm	20,000	K
E200ORT-10	0-20	Nm	0-200	lbf.in	0-200	kgf.cm	20,000	K
E200ORT-11	0-50	Nm	0-500	lbf.in	0-500	kgf.cm	15,000	K
E200ORT-12	0-100	Nm	0-1000	lbf.in	0-10	kgf.m	15,000	K
E200ORT-13	0-200	Nm	0-100	lbf.ft	0-20	kgf.m	12,000	K
E200ORT-14	0-500	Nm	0-200	lbf.ft	0-50	kgf.m	12,000	K

P = Plain, F = Flat, K = Keyed



Technology

An extensively developed measurement principle is used, in which the intensity of light beams is measured by means of photovoltaic detectors, and the electrical output is used to provide precise indication of the applied torque transmitted by the shaft.

The use of this technique results in a transducer being able to sense torque bi-directionally, have a fast mechanical and electrical response, low inertia, and complete freedom from brushes or complex electronics. The absence of brush gear allows high-speed operation with a continuous rating of up to 30,000 RPM standard. Further increases in RPM are available as an option depending upon shaft size. The torque shaft is of low compliance 1/2° maximum torsion deflection on the smaller transducers, and 1/4° maximum on the larger transducers, at full-scale deflection. The lamps providing the light source are selected to ensure long life and high stability with the light intensity automatically controlled within the transducer body by a monitor cell.

Standard

Cable length	2 metres - see options 3&4	Interface readout	E201/2
Outputs	From E201/2 module ($\pm 5V$)	Safe mechanical overload	200% of rating
Power supply	From E200 interface	Memory	Embedded non-volatile memory chip
Accuracy	$\pm 1\%$ FSD; $\pm 0.5\%$ to order	Hysteresis	Better than 0.1%
Bandwidth	50 KHz	Bearings	Deep grooved shielded bearings with oil lubrication-see options 5&6
Temperature range	$-10^{\circ}C$ to $+50^{\circ}C$	Temperature coefficient	Less than 0.05% per $^{\circ}C$

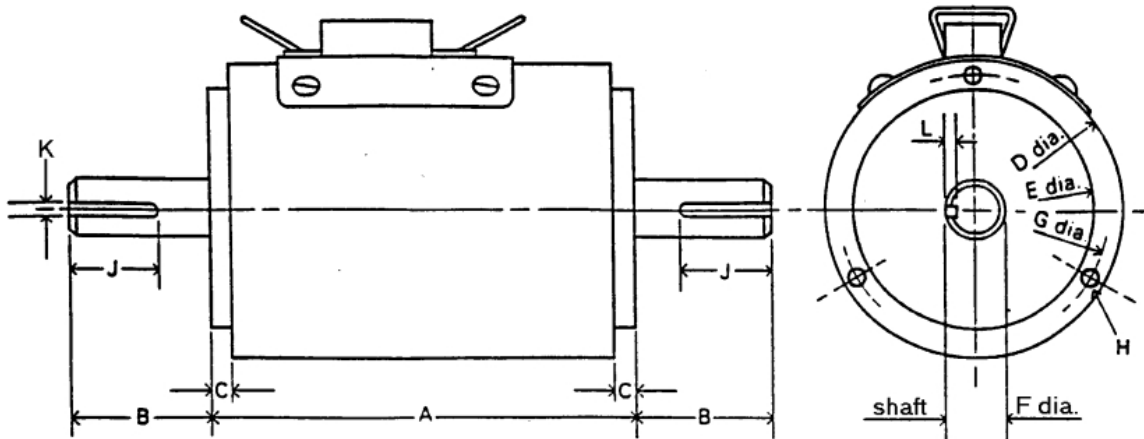

Mechanical Parameters

Model	Dimensions (mm)												
	A	B	C	D	E	F	G	H	depth	J	K	L	
E200ORT-1s- E200ORT-3	75	25.4	1.5	62	50	6.35	56	M3	5	19.05	Plain	0.183	
E200ORT-4 E200ORT-6	75	25.4	1.5	62	50	6.35	56	M3	5	19.05	Flat	0.183	
E200ORT-7- E200ORT-10	105	38	1.5	62	50	12.7	56	M3	6.35	30	3.96	1.98	
E200ORT-11- E200ORT-12	130	60	1.5	62	50	20	56	M3	11	53	6	3.5	
E200ORT-13- E200ORT-14	135	60	4	88	70	30	80	M4	12.7	54	10	5	

Options

Option	Description	Information/remarks
1	Optical RPM Pickoff	External dimensions are not affected
2	Transducer Sealing to IP65	Some external dimensions change. Maximum running speeds will be considerably reduced, and drag torque will increase - Consult factory
3	Extension Cable	Between 2 metres and 10 metres a standard or heavy-duty extension cable may be used. Please specify required length
4	Cable Driver	Between 10 metres and 120 metres, a cable driver is fitted close to the transducer together with an extension lead. Please specify required length
5	High Speed Bearings	At very high speeds, for better balance, we recommend plain or splined shafts - Consult factory See chart below for max speeds
6	Sealed Bearings	See chart below for max speeds

Max speed (Note: quoted in RPM with no radial or side loads)

Option	E200 ORT-1S E200 ORT-6	E200 ORT-7 E200 ORT-10	E200 ORT-11 E200 ORT-12	E200 ORT-13 E200 ORT-14
5	Consult factory	30,000	25,000	20,000
6	15,000	12,000	9,000	7,000
Standard	30,000	20,000	15,000	12,000

Data parameters measured at $20^{\circ}C$

Sensor Technology Ltd reserves the right to change specification and dimensions without notice.

E200 ORT Torque Transducer Display Interface

A Transducer Interface is required with the E200 ORT Series (Optical Rotary Torque) Transducers.

Two models are available, the E201 is a basic transducer display, whereas the E202 is a more advanced unit offering many additional features.



A typical E Series Transducer Display unit. Front panel varies depending on model.

Common Features

- E201/E202 automatically detects and sets the full-scale range of any E200 transducer.
- The display is automatically programmed to read the full scale of the transducer.
- $\pm 5v$ analog output for Torque FSD.
- 90-250V AC or 12V DC operation.

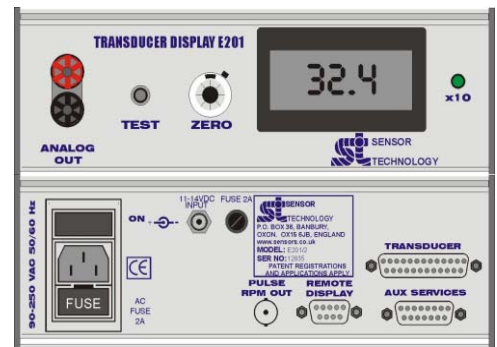

Additional Features for E202

- Operates independently or under control from remote PC.
- Operates with TorqView to give advanced display modes (see TorqView data sheet).
- 2 external analog input channels. (**Option only**)
- Peak readings can be displayed and reset manually or automatically.
- Options menu to allow user to:
 - Set torque limits.
 - Average torque readings.
 - Set instrument display to feature other options (e.g. analog inputs).
 - Fast record facility.

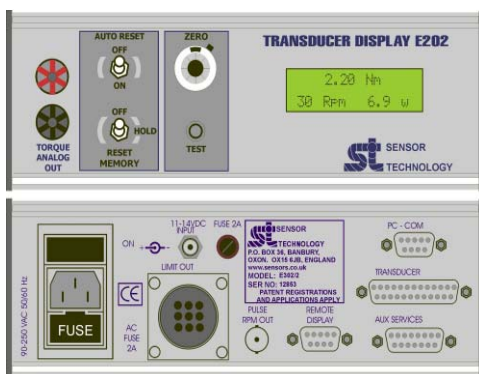

Additional Features for E202 (if Optical RPM pickoff fitted to E200 transducer)

- Speed and power displayed.
- Options menu also allows user to:
 - Average speed readings.
 - Adjust speed output full scale setting.

Display Interface Technical Data and Option Sheet

		E201	E202		
Display Interface Accuracy	±0.1% Digital readout	●	●		
Resolution	0.1% Digital readout	●	●		
	0.05% Analog out	●	●		
Display	LCD (max 1999) with x10 LED indicator	●			
	LCD 16 x 2		●		
Analog Bandwith	50KHz @-3dB	●	●		
Local display update rate	10 times/sec		●		
Overall Size (mm)	220w x 290d x 100h (Aluminium enclosure)	●	●		
Fitted Tilt Feet		●	●		
Weight (nominal)	2.5Kg (5lb 10 oz)	●	●		
Temperature Range	-10°C - 50°C	●	●		
Front Panel (Language)	English	●	●		
				Option	
Power Supply	90-250v AC, 50-400Hz, 20W, IEC connector. 11-14 v DC 1 A 2.1mm jack reverse polarity protected	●	●	1	-
	Power Input - 24v	○	○		a
Torque Analog Output	Analog Output ±5v FSD	●	●	2	-
	Analog Output ±1v FSD	○	○		a
	Analog Output ±10v FSD	○	○		b
	Analog Output +0.5v (fsd ccw) +2.5v(zero) +4.5(fsd cw)	○	○		c
	Analog Output 4-20 mA	○	○		d
Speed Analog Output (Specify RPM FSD required) (Speed pickoff on Transducer reqd)	RPM Analog +1v for FSD		○	3	a
	RPM Analog +5v for FSD		○		b
	RPM Analog + 10v for FSD		○		c
	RPM Analog 4-20 mA for FSD		○		d
Power Analog Output (Specify Power FSD required) (Speed pickoff on Transducer reqd)	Power Analog +1v for FSD		○	4	a
	Power Analog +5v for FSD		○		b
	Power Analog + 10v for FSD		○		c
	Power Analog 4-20 mA for FSD		○		d
Serial Output	TORQVIEW		○	5	a
	RS232		○		b
	Optical Fibre Transmitter for RS232		○		c
	RS 422 Output 4800 baud		○		d
	USB Adaptor		○		e
Auxiliary Inputs	4-20mA		○	6	a
	AC RMS (50-400Hz)		○		b
	Dual Analog inputs + 1v		○		c
	Dual Analog inputs +5v		○		d
	Dual Analog inputs +10v		○		e
External Limit Outputs	Limit output (relay)		○	7	a
	Limit output (opto)		○		b
	Limit output TTL/HC +5v positive logic		○		c
Extended Cable Driver	Over 10 Metres		○	8	a

● – Standard

○ – Option available

Data parameters measured at 20°C

Sensor Technology Ltd reserves the right to change specification and dimensions without notice.