



# **E200 ORT - Optical Rotary Torque Transducer**

## Contents

*Optical Rotary Torque Transducer [E200 ORT]:  
TSE2038R*

*Rotary Torque Transducer Installation Guide: TS3001J*

*Optical Rotary Torque Transducer [E200 ORT]  
Operating Guide: TSE2038R (Includes Introduction,  
Operating Principles, Operating Instructions & Options  
Fitted)*

# E200 ORT Series Optical Rotary Torque Transducer

The E200 ORT Series (Optical Rotary Torque) Transducer offers, in conjunction with an E201/2 Display Interface, an ideal means for precise dynamic measurement of rotary and static torque less than 500Nm and for bandwidths up to 50KHz.

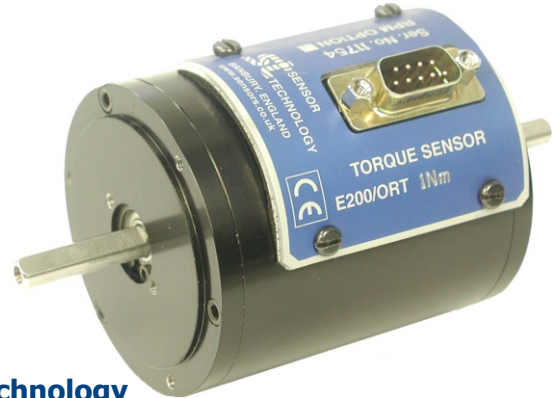

## Benefits

- Operates both statically and dynamically clockwise/anticlockwise
- Non contact measurement
- High bandwidth (up to 50KHz)
- 200% safe mechanical overload
- Low inertia High Speed capability
- E200 ORT Transducers are compatible with our older D Series Instrumentation
- Lifetime warranty

## Software

TorqView is an easy to use advanced torque monitoring software available to assist data recording and instrumentation displays that interfaces with Windows based PCs. See TorqView datasheet.

Features: 3 types of display. Text files compatible with Matlab and Excel. Real time chart plotting.

LabView VIs are available for users to design their own process control applications.

DLLs are also available for users to write own custom software.

## Technology

An extensively developed measurement principle is used, in which the intensity of light beams is measured by means of photovoltaic detectors, and the electrical output is used to provide precise indication of the applied torque transmitted by the shaft.

The use of this technique results in a transducer being able to sense torque bi-directionally, have a fast mechanical and electrical response, low inertia, and complete freedom from brushes or complex electronics. The absence of brush gear allows high-speed operation with a continuous rating of up to 30,000 RPM standard. Further increases in RPM are available as an option depending upon shaft size. The torque shaft is of low compliance  $\frac{1}{2}^\circ$  maximum torsion deflection on the smaller transducers, and  $\frac{1}{4}^\circ$  maximum on the larger transducers, at full-scale deflection. The lamps providing the light source are selected to ensure long life and high stability with the light intensity automatically controlled within the transducer body by a monitor cell.

## Standard Specifications

Model	<b>Full Scale Deflection (Calibration in any of the units below is possible)</b>						
	S.I		F.P.S		M.K.S		Max Speed (RPM)
E200ORT-1S	0-10	mNm	0-1	ozf.in	0-100	gf.cm	30,000
E200ORT-2S	0-20	mNm	0-2	ozf.in	0-200	gf.cm	30,000
E200ORT-1	0-50	mNm	0-5	ozf.in	0-500	gf.cm	30,000
E200ORT-2	0-100	mNm	0-10	ozf.in	0-1	kgf.cm	30,000
E200ORT-3	0-200	mNm	0-20	ozf.in	0-2	kgf.cm	30,000
E200ORT-4	0-500	mNm	0-50	ozf.in	0-5	kgf.cm	30,000
E200ORT-5			0-100	ozf.in			30,000
E200ORT-6	0-1	Nm	0-10	lbf.in	0-10	kgf.cm	30,000
E200ORT-7	0-2	Nm	0-20	lbf.in	0-20	kgf.cm	20,000
E200ORT-8	0-5	Nm	0-50	lbf.in	0-50	kgf.cm	20,000
E200ORT-9	0-10	Nm	0-100	lbf.in	0-100	kgf.cm	20,000
E200ORT-10	0-20	Nm	0-200	lbf.in	0-200	kgf.cm	20,000
E200ORT-11	0-50	Nm	0-500	lbf.in	0-500	kgf.cm	15,000
E200ORT-12	0-100	Nm	0-1000	lbf.in	0-10	kgf.m	15,000
E200ORT-13	0-200	Nm	0-100	lbf.ft	0-20	kgf.m	12,000
E200ORT-14	0-500	Nm	0-200	lbf.ft	0-50	kgf.m	12,000

## Standard

Cable length	2 metres - see options 3&4	Interface readout	E201/2
Outputs	From E201/2 module ( $\pm 5V$ )	Safe mechanical overload	200% of rating
Power supply	From E200 interface	Memory	Embedded non-volatile memory chip
Accuracy	$\pm 1\%$ FSD; $\pm 0.5\%$ to order	Hysteresis	Better than 0.1%
Bandwidth	50 KHz	Bearings	Deep grooved shielded bearings with oil lubrication-see options 5&6
Temperature range	$-10^{\circ}C$ to $+50^{\circ}C$	Temperature coefficient	Less than 0.05% per $^{\circ}C$

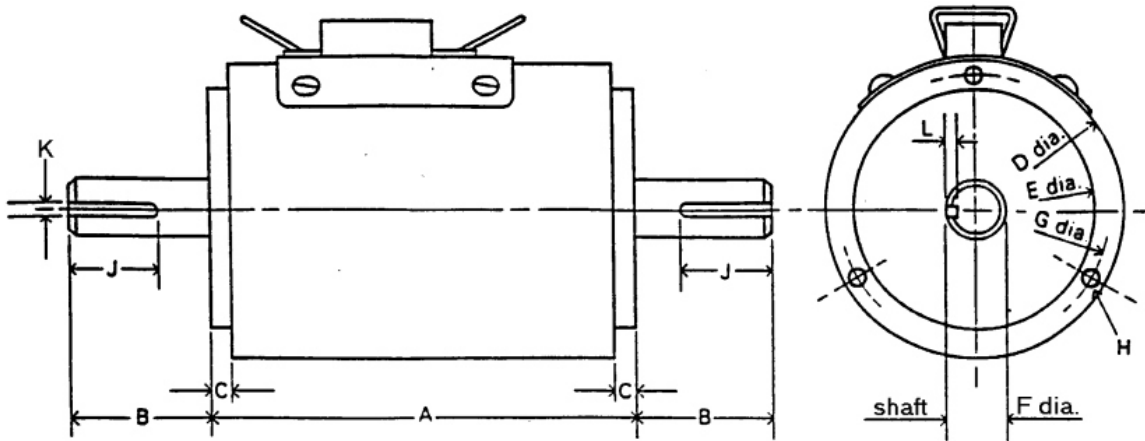

## Mechanical Parameters

Model	Dimensions (mm)											
	A	B	C	D	E	F	G	H	depth	J	K	L
E200ORT-1s- E200ORT-6	75	25.4	1.5	62	50	6.35	56	M3	5	19.05	Flat	0.183
E200ORT-7- E200ORT-10	105	38	1.5	62	50	12.7	56	M3	6.35	30	3.96	1.98
E200ORT-11- E200ORT-12	130	60	1.5	62	50	20	56	M3	11	53	6	3.5
E200ORT-13- E200ORT-14	135	60	4	88	70	30	80	M4	12.7	54	10	5

## Options

Option	Description	Information/remarks
1	Optical RPM Pickoff	External dimensions are not affected
2	Transducer Sealing to IP65	Some external dimensions change. Maximum running speeds will be considerably reduced, and drag torque will increase - Consult factory
3	Extension Cable	Between 2 metres and 10 metres a standard or heavy-duty extension cable may be used. Please specify required length
4	Cable Driver	Between 10 metres and 120 metres, a cable driver is fitted close to the transducer together with an extension lead. Please specify required length
5	High Speed Bearings	At very high speeds, for better balance, we recommend plain or splined shafts - Consult factory
6	Sealed Bearings	See chart below for max speeds

Max speed (Note: quoted in RPM with no radial or side loads)

Option	E200 ORT-1S E200 ORT-6	E200 ORT-7 E200 ORT-10	E200 ORT-11 E200 ORT-12	E200 ORT-13 E200 ORT-14
5	Consult factory	30,000	25,000	20,000
6	15,000	12,000	9,000	7,000
Standard	30,000	20,000	15,000	12,000

Data parameters measured at  $20^{\circ}C$

Sensor Technology Ltd reserves the right to change specification and dimensions without notice.

# Rotary Torque Transducer Installation Guide

To get the best from your RWT310/320 Series or E200 Series Rotary Torque Transducer it is essential that it is correctly installed.

To avoid damaging the transducer during installation it is highly recommended that it is electrically connected and working during this process so that any torque overloads due to handling can be monitored.

For rotary torque transducers **with torque ranges more than 1Nm (10lbf.in.)** it is recommended that the body of the transducer is not rigidly mounted but restrained from rotation using a strap or straps connected to the tapped holes in the end plates. Couplings should be used to allow for angular misalignment while the transducer shaft takes up any parallel misalignment. Care should be taken not to induce any end loads or bending moments to the shaft, as these may induce inaccuracies to the torque measurement and in extreme cases damage the transducer.

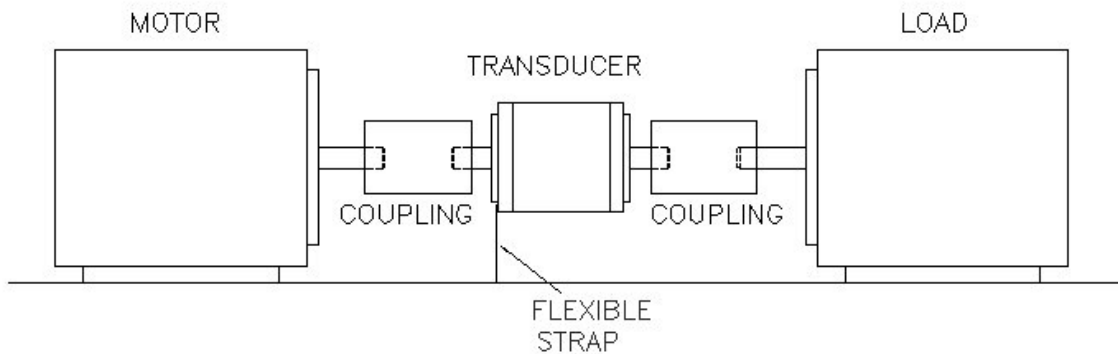

Should rapid variations in torque need to be measured in detail e.g. torque fluctuations in gearboxes or multi vane pumps then it is recommended using torsionally rigid couplings fitted at both ends of the transducer shaft such as single membrane couplings and that these are correctly selected for the transducer rating and speed. An undersized coupling will not transmit the torque while the high inertia of an oversized coupling can result in instantaneous peak torques far in excess of the measured torque. Alternatively, for lower bandwidth applications, where it is more important to measure the 'average' torque rather than fast torque fluctuations, then couplings with a degree of compliance would be more appropriate.

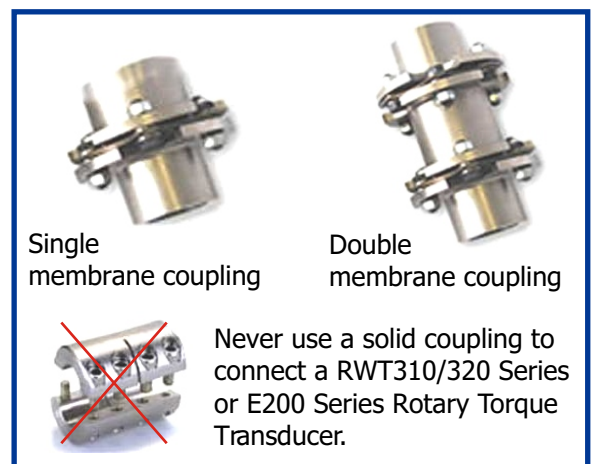

For rotary torque transducers with **torque ranges less than 1Nm (10lbf.in.)**, or rigidly mounted torque transducers, it is recommended that double couplings should be used at each end to compensate for any misalignment of the input/output shafts. The system should be designed to eliminate any end loads on the transducer shaft. For applications where end loads cannot be avoided please consult our Sales Department for advice prior to ordering.

When using a pulley or pulleys it is recommended a bearing block or blocks should be used to ensure bending loads are not transmitted to the transducer.

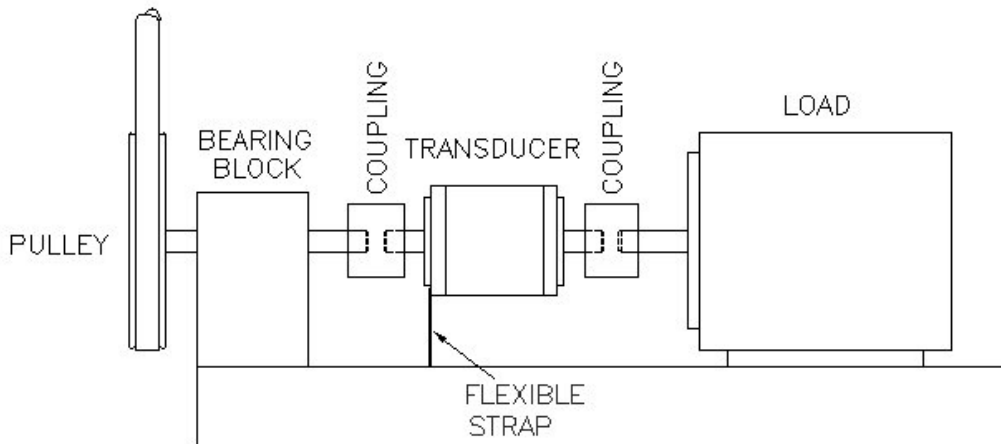

Whilst the transducer is resistant to EMC interference (BS EN 55011), the sensible routing of cables is important to avoid possible EMC interference. Avoid running the transducer cables close, and/or parallel, to high voltage cables, solenoid valves, generators or inverters etc. If the cables must follow the same route as interfering cables then additional screening such as metal conduit should be used to provide isolation. If using an E200 Series or E300 Series rotary transducer with an E Series Display Interface do not attempt to lengthen, shorten or modify the cable between the transducer and the Display Interface. Contact our Sales Department if a longer cable is required.

To avoid damaging the transducer during installation it is highly recommended that it is electrically connected and working during this process so that any torque overloads due to handling can be monitored.

If in doubt, please ask for advice on the installation of your Rotary Torque Transducer via our Sales Department.

Tel: +44(0)1869 238400  
Email: [info@sensors.co.uk](mailto:info@sensors.co.uk)



# Optical Rotary Torque Transducer [E200 ORT] Operating Guide

TSE2038V  
Rev 2

## **1. Introduction**

The Optical Rotary Torque Transducer, in conjunction with the E201 or E202 readout, provides a method of precisely measuring bi-directional rotary or static torque in mechanical systems, and may be supplied with an optical speed sensor for monitoring the speed of rotation of the transducer shaft in dynamic applications, enabling direct measurements of transmitted power to be made on rotating shafts and mechanisms.

The transducer has a low inertia, which results in fast mechanical and electrical response to rapid transients and permits continuous use at high rotation speeds, depending on transducer size.

The transducer must be used in conjunction with an E201 or E202, any transducer being interchangeable with any E201 or E202. Where speed is to be displayed locally, the E202 should be used.

## **2. Operating Principles**

The transducer shaft is connected into the mechanical system on which the measurements are to be made and can spin freely with relation to the transducer body.

Torque applied to the shaft causes an angular deflection in the shaft (approximately 0.5 degree at maximum rated torque). This deflection is sensed by an optical detection system whose output is linearly modulated by the applied torque and it is the modulated light intensity that gives rise to the linear torque output signal.

Torque applied in the clockwise sense along the transducer shaft axis produces a positive polarity output signal while anticlockwise torque gives rise to a negative output. The polarity of the transducer signal is sensed by the E202.

Where an optical rotary speed sensor is fitted, a second light beam is interrupted by the rotation of a disc attached to the transducer shaft which consists of alternate opaque and translucent segments, giving rise to pulse modulation of the speed – sensor beam, which in turn produces a modified through zero crossing at the “RPM OUT” socket of the E201 or E202.

## **3. Operating Instructions**

Connect the 9 pin “D” socket of the interconnection lead to the 9 pin “D” plug of the torque transducer ensuring to secure the plug with the clips provided on the transducer body. Plug the other end of the lead into E201 / E202 transducer socket. Switch on the E201 / E202 and allow five minutes for the equipment to reach thermal equilibrium. Zero the transducer output using the E201 / E202 “Zero” control which should be at approximately half way position (5). The transducer is now ready for use.

Each E200 ORT transducer must be connected to the E201 / E202 with its own lead, identifiable by the matching serial number on the 25-pin plug end of the lead.

**THE SERIAL NUMBER OF THE LEAD MUST MATCH THE E200 ORT SERIAL NUMBER.**

The lead contains calibration information on the E200 ORT, which is reported to the E201/E202 to give the correct scaling on the display. The E201 will only display torque. The E202 will display torque, and if a speed sensor is fitted to the E200 ORT, it will display speed and computed power.

#### **4. Options Fitted To Your Transducer**

##### **E200 Serial Number**

No options fitted.